



Dynisco PolyClean

Fluidized Temperature Bath

Operating Manual



TABLE OF CONTENTS

Introduction	3
Warnings & safety	4
Installation	5
Specifications	7
Operation & cleaning temperatures	9
Procedures for cleaning PVC	12
Fault finding & Parts list	13
Wiring Diagrams	15
Exhaust diagrams	16
CE Declaration of Conformity	20



INTRODUCTION

Fluidized Temperature Baths have been in use for decades as a temperature source for many heating applications such as thermal cleaning, heat treatment, calibration, thermal analysis, process heating and laboratory reactive heating. It is important that this instruction manual be made available to all operators who may come in contact with the system. All operators should read this manual from beginning to end and observe all safety warnings and symbols. In particular, we would stress the importance of standard, commonsense rules and adherence to normal, safety standards and procedures. Maintenance and/or service should only be performed by a qualified electrician or engineer. **If there is any doubt whatsoever relating to the proper use of this equipment, please contact us.**

The Fluidized Temperature Bath consists of a stainless steel tank and top cover that is surrounded by a powder coat painted outer case. This tank either contains or is surrounded by electrical heating elements and is wrapped with an insulation blanket. Temperature and air control systems as well as other electrical components are housed with a forced air cooled control cabinet that is mounted on the side. The temperature of the fluidized temperature bath is set and maintained by temperature controller, which receives an electrical signal from a type "K" thermocouple placed along the fluidized bath container inner wall. Current to the heating elements is switched on and off by means of solid state relay actuated by the temperature controller. The controller has a resolution of 1° and can be switched between °C and °F.

The systems are supplied with independent over-temperature protection via a 2nd thermocouple junction that will disable power to the heaters in the event that one of the following conditions occur; thermocouple failure, loss of power to or controller fault and/or exceeding the factory set high temperature limit of 618°C(1145°F). The internal controller will flash a message when one of these conditions has occurred and/or light up the front panel neon light labeled "Overtemp".

Air enters into a seam welded air chamber in the bottom of the tank that causes the aluminum oxide to Fluidize. The air supply to the Fluidized bath must be clean and dry and adjusted to supply a constant 40 PSI/2.7 bar of pressure at a maximum flow of 3.5 CFM/99LPM. An air filter and pressure regulator can be supplied as optional equipment. Air flow to the Fluidized Bath is controlled automatically by 3 solenoids which are connected to 4 needle valves to set and control air flow at various temperature points. Alarms ALM1, ALM2 and ALM3 are used to control air flow and are not indicative of any fault condition.

WARRANTY

This product is covered by a 1 year factory parts and labor warranty. It must be clear that **Dynisco** and our suppliers are not insuring your products/premises or guaranteeing that there will not be damage to your person or property if you purchase our Products. **Dynisco** or our Suppliers shall not be liable under any circumstances for damage to your person or property or some other person or that person's property by reason of the sale or use of the product we sell, or its failure to operate in the manner in which it is designed. **Dynisco** and our Suppliers liability, if any, shall be limited to the original cost of the Product only. Use of this Product is at your own risk. Buyer assumes full responsibility in determining the suitability of these items for buyers intended use. It must be clear that the Warrantors are not insuring your products/premises or guaranteeing that there will not be damage to your person or property if you

use products purchased from **Accurate Thermal Systems**. **WARRANTORS' OBLIGATION UNDER THIS WARRANTY IS LIMITED TO REPAIR OR REPLACEMENT OF THE PRODUCT ONLY. THIS WARRANTY DOES NOT COVER PAYMENT OR PROVIDE FOR THE REIMBURSEMENT OF PAYMENT FOR INCIDENTAL OR CONSEQUENTIAL DAMAGES.**

WARNINGS AND SAFETY

Please read this entire manual before operating the Fluidized Temperature Bath. If used improperly a serious personal injury can occur and/or cause damage to the system. Our products are designed and manufactured to conform to internationally recognized safety standards and requirements. Accurate Thermal Systems, its representatives, vendors and distributors assume no liability for the operation of this product in an unsafe manner. Use common sense and adhere to all warnings and cautions during use

High temperatures can cause serious burns and ignite combustible materials. Please be aware of and conform to the following. The symbols shown may appear in this manual or on the product.



HOT SURFACE



ATTENTION



DANGER HIGH
VOLTAGE



PROTECTIVE
CONDUCTOR TERMINAL

WARNINGS

- **WEAR PROTECTIVE GLOVES** that are rated for 1000°F/525 °C that cover your hands and arms up to the elbow
- **DO NOT** use the system near flammable liquids or gases
- **Provide at least 12"/305mm** of open space around the system and 4 ft/1200mm above it to prevent surrounding objects from getting hot.
- After removing parts, baskets and any other heated items from the system remember that they may be **VERY HOT**
- **Never add cold aluminum oxide sand** to the Fluidized Bath when it is above 400°F/200 °C
- **Eye goggles** that are not vented should be worn when working with the system to protect eyes from heat and aluminum oxide sand

CAUTION

- **DO NOT** use the Fluidized Bath if the control box fan is not running
- **DO NOT** operate the system if it is not Fluidizing/bubbling or it appears that a portion is not Fluidizing as normal
- **DO NOT** place any fluids or liquids directly into the bath
- **DO NOT** use the Fluidized bath if the surrounding area or floor becomes wet
- If the **"OVERTEMP"** light comes on, **DO NOT** shut off power but instead contact maintenance or a qualified technician immediately.
- In the event of a power loss leave the air supply on and flowing if possible

PACKAGING, HANDLING & TRANSPORTATION

Inspect all shipping containers for signs of damage which may have been caused by rough handling in transit. Immediately take pictures of any damage to the packing. If the packaging is damaged carefully unwrap all items to inspect for damage. Also take pictures of any damaged product and then immediately contact the Freight Company and Accurate Thermal Systems.

Remove the packing list and verify that all ordered items have been received. If there are any questions about the shipment, please call Dynisco at 1-800- Retain the cartons in which the bath was received until the unit is tested and found to be in good condition.

Fluidized Temperature Bath Systems weigh in excess of 120lbs/55kg and should only be moved by using a hand truck, pallet jack or fork lift. When transporting a system it must be palletized on a suitable skid due to the weight and size.

INSTALLATION



1. The bath should be placed in a location that is level and dry. Check the system for levelness. It should be located in an area where suitable power and air are available.
2. For thermal cleaning applications the system installation should be in an area within close proximity to an exhaust hood or exhausting pipework for removing of fumes and smoke. See the diagrams on PAGE 19 for more details on exhausting.
3. Due to the radiated heat from the system install in a location that allows at least 12"/30cm of clearance on the sides and 4ft/122cm above to prevent surrounding objects from getting hot.
4. Connect an air supply set to deliver a constant 40 PSI/2.7 BAR at maximum flow of 3.5 CFM/99 LPM. The supply should be dry and free of particulate. **An air supply that is not dry can cause damage to the system and/or components that are immersed into it.** Contact us for assistance with air filtering and drying. A 6ft/180cm length of 3/8"/10mm OD rigid tubing should be used to connect the air supply to the bath via the quick disconnect fitting on rear of the control box.
5. Before connecting to your electrical supply verify that it meets the specifications for the unit as shown on the rating plate. **The requirements below must be met to maintain safety to equipment, personnel and property. ALL ELECTRICAL CONNECTIONS MUST BE MADE BY A QUALIFIED ELECTRICIAN OR ENGINEER.** The system is supplied with a 10ft/305cm length of appropriately rated power cable for each specific model. Below are recommended wire sizes for the power feed up to the breaker panel and the recommended breaker ratings.

Model	Supply conductor size to breaker panel – 300 volt rating	Switchable panel breaker rating
PC-FB-12L	12 gauge or 3.31mm ²	20 amps/ 250 VAC
Fluidized Bath wiring connections		
Live	Black	
Neutral	White	



Green	Earth (PE)
<p>The system requires a single phase, 50/60hz supply that is capable of delivering between 220 and 240 VAC under load at the rated current. <u>A supply below 220VAC under load is too low and can cause component damage and increase heat up times.</u></p>	
<ol style="list-style-type: none"> 6. Fill the bath with Aluminum oxide sand to within 4"/10cm (FTBLL12) 5"/13cm (FTBLL26) of the top adhering to safety guidelines on page 2. Immersed parts and objects may displace the aluminum oxide causing it to rise so adjust accordingly. 7. Turn on power and air to the unit, 1 power switch is on, 0 power switch is off. Use the up and down arrows to set the controller to your operating set temperature. You must press  for your set point to be accepted. When Fluidized and bubbling make sure the Aluminum oxide sand level is maintained per step 6. Air must be flowing to the bath at all times when the temperature is above 200°C/400°F. 8. The green heater neon will light up when power is applied to the heaters. 9. Place the extraction collar (if purchased) into the bath and place the lid on. 10. IMPORTANT: Once the controller has reached your set temperature and the heater light is flashing allow 1 hour for the bath to fully stabilize before use. 11. NOTE: Alarm LED's ALM1, ALM2 & ALM3 on the temperature controller are used for air control and are not indicative of a fault. 12. With your first tool cleaning start with a smaller number of tools and at a lower temperature. Adjust the bath set temperature and the number of tools cleaned based on your expected results and the amount of time required. It is always a good idea to clean at the lowest possible temperature. 13. Extraction Air setup; if you use an exhaust hood for ventilation this step doesn't apply to you. <ol style="list-style-type: none"> a. Make sure the exhaust system is laid out according to our recommendation in this manual on page 19 b. Turn the exhaust fan on and close the damper so there is no extraction to the bath c. Put parts in basket and lower into the bath d. Place lid on the bath e. When smoke and fumes start to come up and around the lid slowly open the damper just to the point where they are pulled back into the exhaust system and no longer enter the operating area, then stop adjusting and tighten the damper in place. f. This setting will give good results with minimal heat and sand loss 14. After repeated tool cleanings heavier clumps and larger particulate should be sieved from the sand. See optional accessory ATS1041 in the accessories list. 15. In time the sand may become dense and fluidize poorly at which point it should be replaced. 16. The bath air supply and power can be turned off after the temperature has cooled to 200°C/400°F 17. Alternatively we suggest using the available Windows software to setup a schedule whereby 	



your operating temperatures are controlled automatically by the PC and software.

TECHNICAL SPECIFICATIONS

- Overall external dimensions: length: 21"/53.3cm
 width: 24"/61cm
 height: 27"/68.5cm

- Bath internal dimensions: 10.0"/25.4cm diameter
 16.0"/40.6cm deep

- Working volume: 10.0"/25.4cm diameter (8.4"/21.3cm diameter when using parts basket)
 12.0"/30.5cm deep

- Temperature range: 50°C to 605°C (122°F to 1121°F)

- Temperature stability: ±1.0° C (8"/20cm immersion depth, with lid on after 2 hours controlling
at set point)

- Display accuracy: ±5.0° C (8"/20cm immersion depth, with lid on after 2 hours controlling
at set point)

- Heat up time*: Ambient to 900°F, 480°C – 2.0 hrs

- Air supply: Clean, dry and oil free air, at a constant pressure
 of 40 psi/2.7 bar, max flow of 3.5 CFM/99 LPM using a 3/8"/10mm OD
 rigid tubing plugged into the quick release fitting on the control box.

- Fluidizing bath media: Aluminum oxide 85lbs/38.6 kg

- Electrical requirements: 240V, 1 phase, 60Hz, 4.5kW, 18.7 amps, fuse rating 20 amps/250V

- Exhaust fan requirements: 250 ft³ /min. at 1 in W.G.

- Gross weight: 195 lbs/88.6 kg

- Net weight: FTBLL12 - 110 lbs/50kg
 Alum Oxide - 85 lbs/38.6 kg

- Operating Ambient: 10 ° C/50 ° F to 40 ° C/104 ° F, 80% RH max.

* Indicated heat up time applies for a well fluidized bath with a lid on, extraction fan off and power supply voltage of 220 to 240 VAC under load. Note that a supply voltage below these values can damage the solenoid valves and reduce heat up time and bath performance.



OPERATION

The FTBLL Fluidized baths in this manual were designed specifically for "burning off" or thermally removing residue from plastic machinery tools. The FTBLL baths are also a good choice for many heat treatment, reactive chemistry, calibration and exothermic reaction type of applications.

Our systems are effective on all plastics, including polyethylene, polypropylene, PVC, nylon, polyester, polycarbonates, acrylic, Peek, PTFE, polystyrene and acetyl. In addition, they are effective with rubber, EPR, epoxy resins and acrylic paints. They provide a safe, dry and fast means of removing all plastic residues with a minimum amount of effort. The "burning off" operation is controlled at a uniform temperature so that distortion is avoided. Furthermore, the fluidized temperature bath is non-abrasive, so physical damage to parts is minimal which extends tool life.

The cleaning process itself is very simple using the heat transferred from the fluidized bath to the tools to degrade the plastic residue. Parts are placed in a mesh basket for ease of handling, then lowered into the fluidized bath, operating at a temperature between 800°F (425°C) and 1020°F (550°C) depending on the polymer, for approximately 30 to 60 minutes. Actual burn off times and temperatures vary depending upon the weight, material being removed and overall quantity of residue on the part.

BATH TEMPERATURE

The bath should be allowed to stabilize for at least 1 hour after the controller has reached the set point temperature before using the bath. An initial temperature drop or quenching of the bath can occur after inserting objects into the bath. This temperature drop depends on the size of the immersed object, but is generally in the order of 27°F (15°C). Polymer is reduced to ash and carbon dioxide quickly above 752°F (400°C). It may be found desirable to pre-heat the bath to as high as 1020°F (550°C) in order to obtain quick results, but caution should be exercised not to damage tools by overheating or to cause a flame up due to combustion of polymer and fumes.

THE CLEANING PROCESS

The first two thirds of the total time required for tool cleaning, sees the plastic reduced to a tar mix state. In this phase, all the initially combustible products of the plastic leave the bath through an appropriate fume extraction system. In the last third of the immersion time, the tar mix state is reduced to carbon which either burns away or remains loosely bound to the tool. In the latter case, it can be blown off with shop air or lightly brushed off with a wire brush or Scotch Brite pad after the part is removed from the fluidized temperature bath. The clean part can then be set aside to cool or be placed in the optional cooling stand and sieve accessory (PC-FB-CLRACK) before being used or returned to the tool room. In some cases, dies may need to be wiped off or polished gently with a soft cloth.

The aluminum oxide fluidizing medium is not degradable but will need to be replenished due to loss during operation or extracted in the exhaust. In the particular case of PVC, chlorinated hydrocarbons remain in the fluidized bath after burn off which dictates special maintenance procedures. When removing PVC we recommend leaving the system to run at lower temperatures (100°C/200°F) when not in use to minimize moisture ingress into the aluminum oxide which can increase Hydrochloric acid levels in the bath resulting in oxidation and damage to metal components.



TYPICAL CLEANING TEMPERATURES

The following table details recommended operating temperatures for particular Polymers. The temperatures quoted should be used as an initial guide only. The ideal operating temperature will vary depending on the size of the parts and the amount of material being removed. Temperatures below 400°C/750°F should be avoided to eliminate the danger of the polymer melting and sinking to the bottom of the bath where it may block the porous plate. With large objects it is desirable to heat the bath to above the operating temperature so that the polymer rapidly moves through the melting phase to the burning condition. Excessive operating temperatures should be avoided as they increase the fume concentration and may result in a flame up of the parts in the bath.









Use as a guide & starting point only. Always use the lowest temperature that gives satisfactory results

Material Burn-off temperature °C/°F

Nylon 450/842	Paint 475-575/887-1067	Styrene 450/842
Polyethylene 425-450/797-842	Polypropylene 425-500/797-932	Fluoropolymers 525/975
PTFE 500/932	PVC 460-540/860-1004	High density polythene 450/842
PEEK 500-525/932-977	Silicone Rubber 535/995	Polyesters 450/842
Ethylene methacrylic 450-480/842-896	Polyurethane 440-450/824-842	Polystyrene 450/842
Rubber debonding 350/662	Polycarbonate 400-425/752-797	Organic matter oil/grease 300-500/572-932
Crosslink PE 400/750		

PID TEMPERATURE CONTROLLER

The control parameters in the PID temperature controller have been optimized by the factory to give the best results for most applications.

- 1) To change the set point use the up/down buttons to set a value. The  key can be used to switch between display digits for fast set point changes. Press  to accept any changes.
- 2) The controller has been locked out to prevent accidental parameter changes. This is confirmed by the key symbol  in the display.
- 3) To unlock the controller press the  key and the down arrow at the same time. The display will show **KEYP**. Use the up arrow to select all zeros 0000 and then press .
- 4) Press the  key to access the **PVOF** parameter which is used to set a calibration offset. This can be used to correct any errors between an independent thermometer and the controller display.
- 5) To lock out the controller, press the  key until **LoC** is displayed. Use the up arrow to select **LoC2** and then press .

PC SOFTWARE FOR WINDOWS

A PC software package for Windows is available for free download from our website. This software allows you to remotely control the bath temperature, display a temperature graph and put the bath on a weekly operation schedule whereby it will follow the program you create and cool down to a set temperature after hours and then heat up and be ready for operation in the morning.



FUME REMOVAL

See the diagrams on page 19 for examples on designing a fume exhaust system. When the Fluidized Temperature Bath is installed with a fan and exhaust ducting system, fumes will be removed from the top of the fluidized bath or through the extraction collar depending on the exhausting layout used.

The Cyclone is used to capture any sand and heavier particulate from the exhaust stream before being vented away from the system. We have three different potential system layouts for venting and exhausting fumes and smoke from the work area.

PC-FB-CYCLONE -

An efficient in-line unit for removing aluminum oxide media and heavy particulate from the exhaust fumes.

PC-FB-HEPA-FLTR-V - DCS2500 Vertical Air Filtration System.

PC-FB-HEPA-FLTR-H - DCS2500 Horizontal Air Filtration System.

OPERATOR BASIC MAINTENANCE

The control box cooling fan should be cleaned out with shop air periodically to keep it free from dust and particulate.

The aluminum oxide, not being degradable, will only require replacement when losses occur due to attrition, spillage or when becomes contaminated with carbon and ash. Note that the aluminum oxide pulled out of the bath through the exhaust duct can be captured for reuse with the "cyclone" option (PC-FB-CYCLONE).

On at least daily intervals, the bed should be cleaned of floating residues by means of a wire mesh hand sieve or conventional kitchen hand strainer. This procedure removes carbon char clumps which impairs fluidization and acts as an absorbent. More importantly, it can also remove uncharred plastic and so reduce the quantity of fumes produced and the time of processing. If you find clumps in your bath in daily use in should be emptied monthly to check for buildup of clumps and heavy deposits in the bottom of the tank.

The optional air-line filter/regulator into the bed is self-draining. However, it should be kept in good condition by inspection at two week intervals and by cleaning the bowl and washing or replacing the filter element as necessary. With exceptionally dirty or wet air supplies this frequency may have to be increased. Water or water vapor in the air supply is a notorious source for the production of hydrochloric acid in the bed when PVC is burned off. In addition, oil vapors in the air supply which reach the fluidizing plate are carbonized within the pores of the plate, quickly causing blockage and consequent poor fluidization. Corrosion of processed parts could be seriously increased if they are left immersed overnight. Furthermore, residual plastic, instead of being burned off in a fluidized state, could percolate down through a static bed and settle on the porous plate causing blockage and poor fluidization.

All ventilation ductwork and components should be visually inspected every 3 months for signs of



buildup and possible blockage. A buildup of oil and grease from pyrolyzing plastic in the ductwork can be a fire hazard and should be cleaned or the ductwork replaced.

If the bath is left unused for long periods of time, empty the aluminum oxide and store it in a separate container. Keep the inside of the bath clean and dry.

SPECIAL OPERATOR MAINTENANCE PROCEDURE WHEN BURNING OFF PVC OR OTHER HALOGENATED POLYMERS

Burning off PVC (polyvinyl chloride) and Fluoropolymers in a Fluidized Temperature bath offers one of the most severe conditions of operation. Hydrogen chloride (HCl) liberated on the breakdown of PVC is absorbed by the bed medium creating an acidic environment within the bed. This happens especially when the bed also absorbs water from the atmosphere or when the fluidizing air is cold. HCl is extremely corrosive, especially when it is aerated and wet. In addition, in water it produces chloride ions which, even in neutral or alkaline solutions, promote corrosion and rusting in steel. A common example would be the corrosive nature of sea water and calcium chloride road deicer.

Consequently, fluidizing baths used for burning off PVC require maintenance to minimize corrosion of the bath and of parts cleaned in it, especially if they are not stainless steel. The purpose of most of the recommended maintenance procedures is aimed at keeping the bed medium clean, free-flowing, free of gums, acid, partly decomposed plastic, char and larger particles. These cleaning processes have the additional benefit of ensuring good fluidization and thus good heat transfer throughout the bed and into immersed parts. This, in turn, reduces burn-off time, uneven heating of parts and thus distortion, increases heater life by eliminating localized hotspots and makes cleaning easier on a regular basis.

The following procedures are essential when PVC is burned off on a regular basis, but they can also be followed by users of other plastics.



The bed should be completely emptied at monthly intervals and visually inspected for signs of corrosion. Examination should include the walls of the inner cylinder, the porous fluidizing plate, the thermocouple sheath and the loading baskets with particular emphasis on exposed weld lines. Serious corrosion should be dealt with immediately by improving maintenance procedures or by replacing the inner container before holes appear and cause failure of the heating element and corrosion in more inaccessible parts.

The aluminum oxide should be sieved with a 50 mesh screen on at least monthly intervals to remove any gummy material, clumps of carbon and ash and then periodically it should be completely changed out with new media.

During shutdown overnight or over the weekend, the temperature should be reduced to 100°C/200°F to ensure that the moisture from the atmosphere is not condensed into the bed to create hydrochloric acid. Fluidizing air should always be kept on. For extended shutdowns exceeding two days, the medium should be removed and the inside of the bath wiped out with a wetted 5% washing soda solution (sodium carbonate) to help neutralize any acid.

FAULT FINDING & MAINTENANCE

Fault finding, electrical troubleshooting and maintenance should only be performed by **qualified electrician or service engineer**. Always make sure the power supply is disconnected with a lockout notice in place before replacing parts. Refer to the spares list on the next page for any parts that are required.

 	1. Poor or no Fluidization – remove aluminum oxide from bath leaving approximately 2 inches in the bottom. If an area ¼ or more is not bubbling then most likely the porous plate is blocked and should be replaced. Check that the porous plate is not blocked with plastic residue or other material. Verify air supply is set to 40 PSI. If OK, see step 11.
	2. Slow heat up – Check current draw of the heaters. FTBLL12 at 240volt should be around 18 amps. The FTBLL26 should be 25 amps. Also check that air is flowing at the rates indicated on page 8. Note the flows that should be observed at each temperature range.
	3. Thermocouple fault – if a open sensor alarm is shown on the controller then check with an instrument that can measure and simulate thermocouple signals to verify its operation. If open then replace the thermocouple
	4. “OVERTEMP” light is on - indicates that an over temperature condition has occurred or the limit thermocouple has failed. First verify that air is flowing into the bath and that it is well fluidized with flow rates shown in the table below. Next check to see that the thermocouple connected to the open PCB limit controller on pins 3 & 4 has not failed. Finally make sure that the solid state relay passes current only when a DC signal is output by the controller. The fault condition can be cleared by shorting terminals 1 and 2 on the limit control PCB.
	5. No heat – verify heater current. The FTBLL12 should measure 18 amps and the FTBLL26 close to 25 amps. If no current check heater resistance, FTBLL12 = 13 ohms, FTBLL26 = 9 ohms. If OK go to step 6.
	6. No heat – the controller will output a DC signal to the SSR when heat is called for. If the solid state relay is receiving a DC control signal but not passing power to the heaters then it should be replaced. If OK, go to step 7
	7. No heat – verify that the contactor coil has voltage across it and that the contacts are closing
	8. Bath temperature is not accurate, parts not being cleaned – if you suspect that the bath temperature is off it can be checked with a handheld thermocouple meter. Do not use an IR thermometer to measure the sand temperature. If inaccuracy is verified refer to step 1 and 2. If OK the control thermocouple should be checked and replaced is necessary.
	9. Combustion occurs and parts flame up – reduce operating temperature by 20°C/40°F increments until it doesn’t happen again.
	10. No controller display – check the two fuses on the back of the control box.
	11. Flow rates not meeting table below – verify that the 3 solenoid valves are receiving power from the controller and replace as necessary.



FLUIDIZING AIR ADJUSTMENT

The system automatically controls the Fluidizing Air to the bath at all times. It is a very reliable and flexible setup however the user can make adjustments to optimize the Fluidization as needed.

The controller is set up with factory defaults to give satisfactory results based on the temperatures and flow switch points shown below. In general it is always preferable to be over-Fluidized than under.

<u>Indicated bath temperature</u>	<u>Alarm LED</u>	<u>Needle Valve</u>	<u>Flow rate – CFM FTBLL12</u>	<u>Flow rate – CFM FTBLL26</u>
up to 174°C (345°F)	ALM1, ALM2, ALM3	1, 2, 3, 4	3.5	3.6
175°C (347°F) to 324°C (616°F)	ALM2, ALM3	1, 2, 3	3.0	3.2
325°C (617°F) to 434°C (813°F)	ALM3	1, 2	2.4	2.6
435°C (815°F) to 605°C (1121°F)	None	1	1.8	2.0

Wiring Diagrams

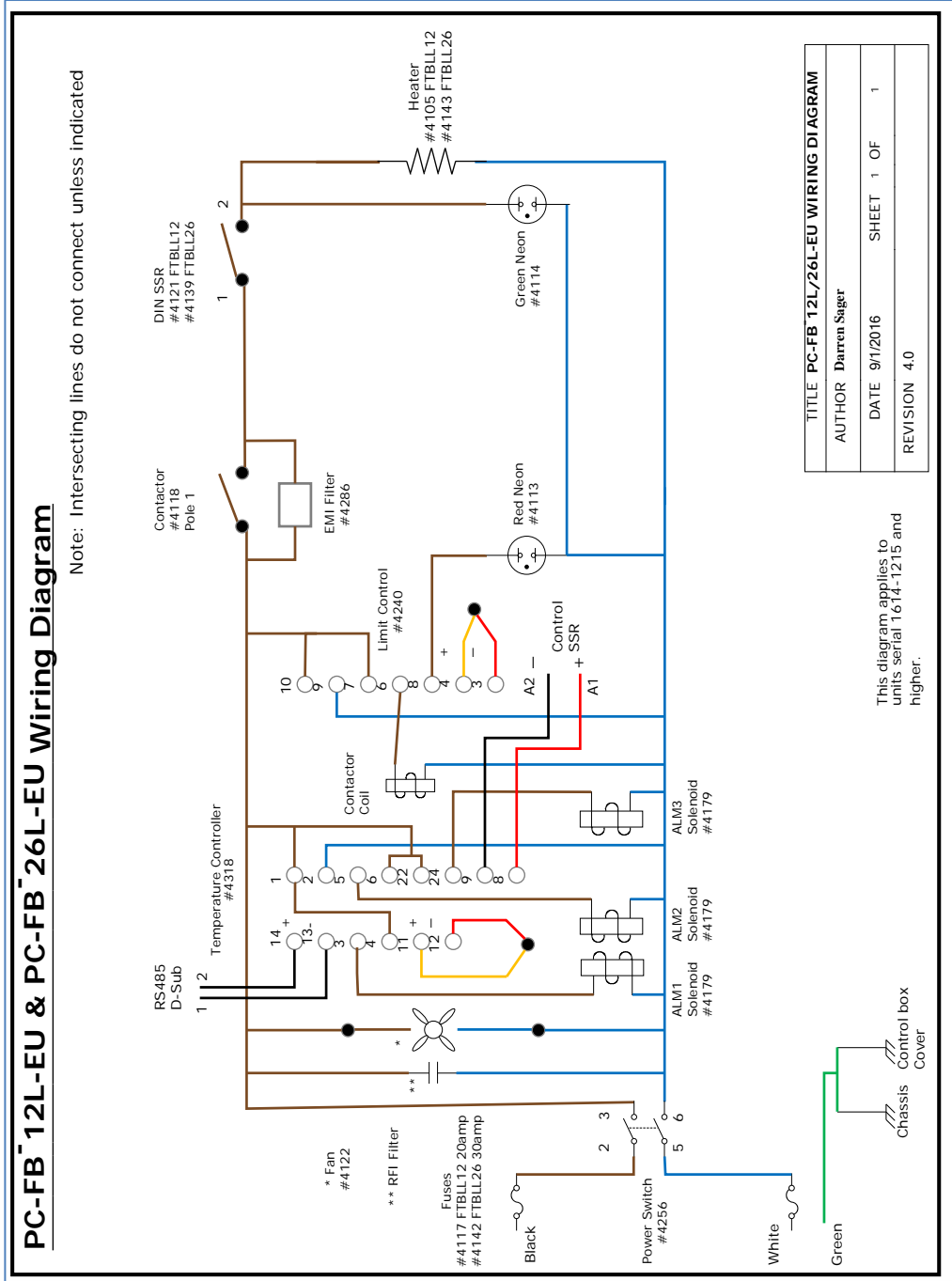

Fume Exhaust Diagram #1

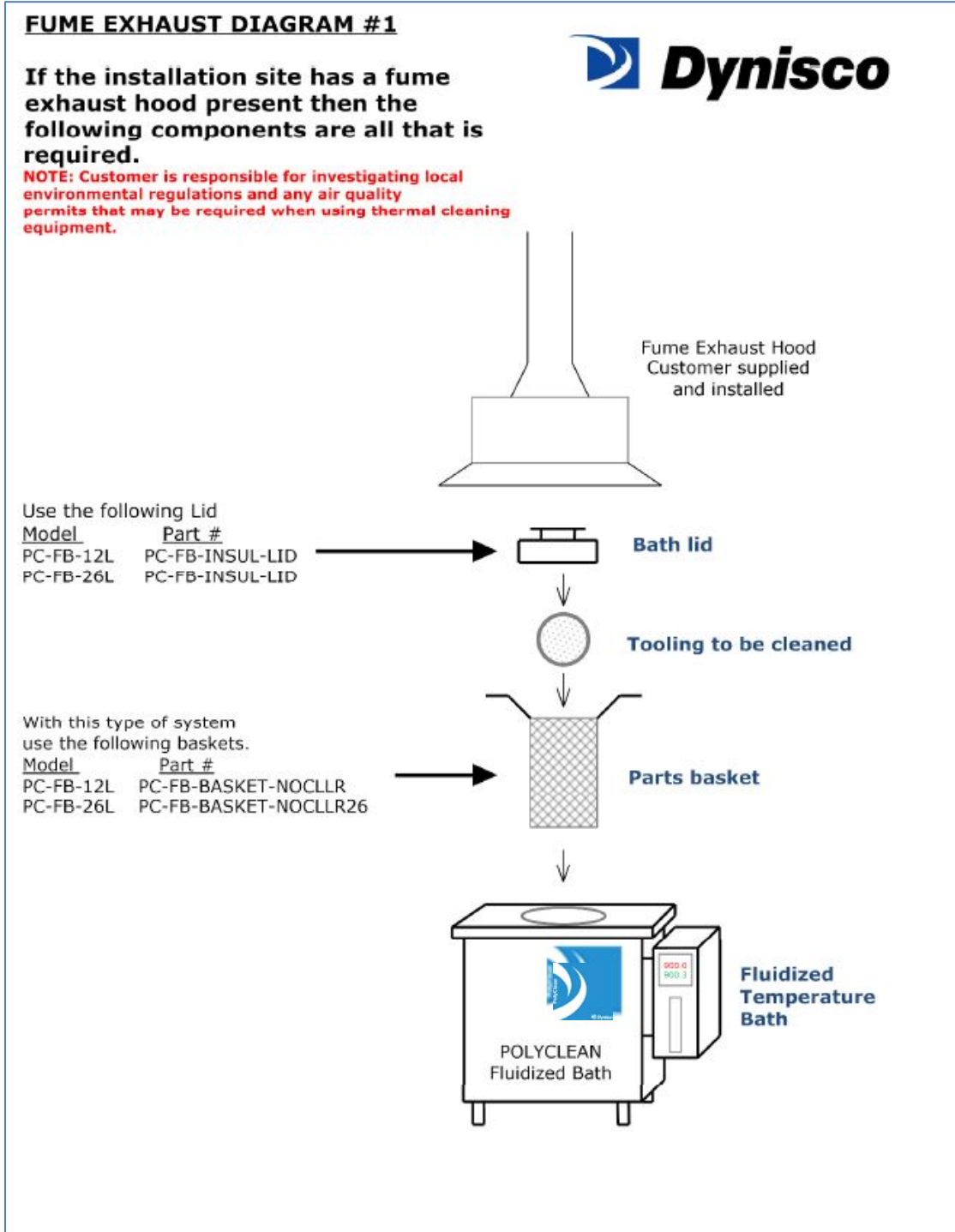

Fume Exhaust Diagram #2

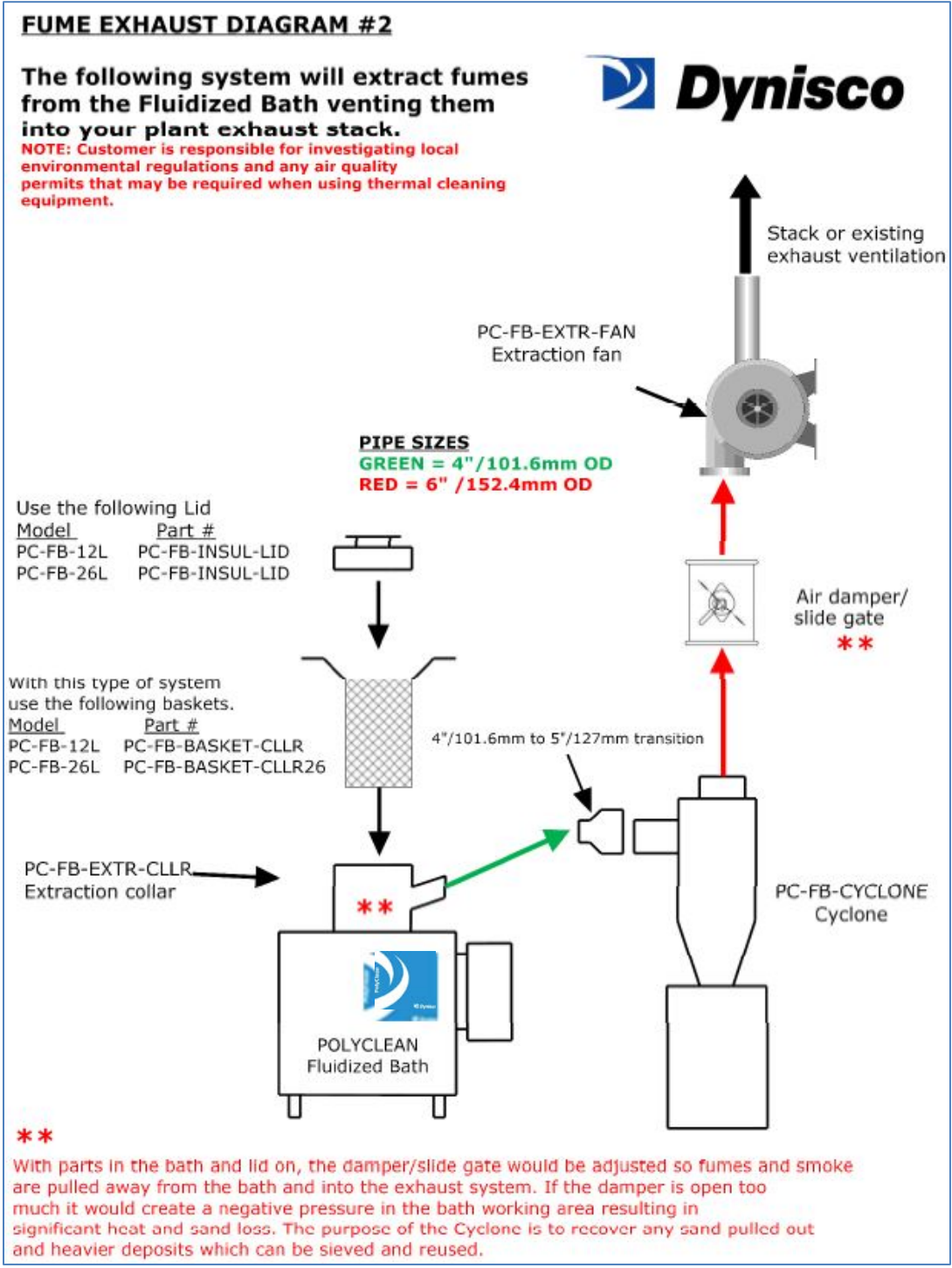

Fume Exhaust Diagram #3

DIAGRAM #3

The following system will filter out fumes and smoke from the exhaust stream for venting outside or into the plant stack. Contact www.ductincorporated.com for any transitions, fittings or ductwork needed



NOTE: Customer is responsible for investigating local environmental regulations and any air quality permits that may be required when using thermal cleaning equipment.

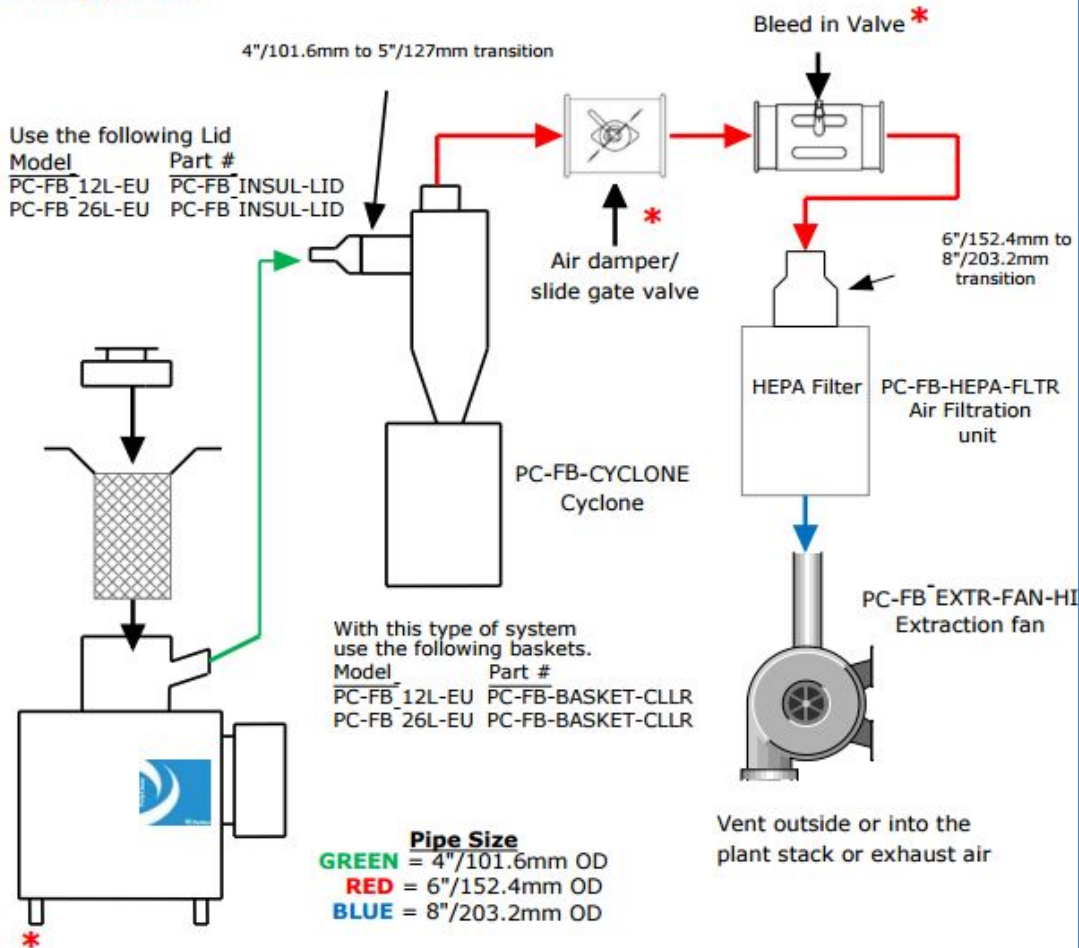

* With parts in the bath and lid on, the damper/slide gate valve would be adjusted so fumes and smoke are pulled away from the bath and into the air filtration system. If the damper is open too much it creates a negative pressure in the bath working area resulting in significant heat and sand loss. The purpose of the Cyclone is to recover any sand pulled out and heavier deposits which can be sieved and reused. The bleed in valve is opened to cool down the exhaust air stream before entering the filtration unit.



EC Declaration of Conformity

In accordance with EN ISO 17050-1:2004

We Dynisco
of 38 Forge Parkway Franklin, MA 02038

in accordance with the following Directives:

2006/95/EC	The Low Voltage Directive
2004/108/EEC	The Electromagnetic Compatibility Directive
2011/65/EU	The Restriction of Hazardous Substances Directive

hereby declare under our sole responsibility that:

Equipment	Fluidized Temperature Bath
Model numbers	PC-FB-12L-EU

is in conformity with the applicable requirements of the following documents:

Ref. No.	Title	Edition/date
BS EN 60519-1	Safety in electroheating installations. General requirements	2011
BS EN 61000-6-2	Electromagnetic compatibility (EMC). Generic standards. Immunity for industrial environments	2005
BS EN 61000-6-4	Electromagnetic compatibility (EMC). Generic standards. Emission standard for industrial environments	2007 + A1:2011

I hereby declare that the equipment named above has been designed to comply with the relevant sections of the above referenced specifications. The unit complies with all applicable Essential Requirements of the Directives.

Signed by: John Czazasty

Name: John Czazasty
Position: Director, Engineering
Done at Dynisco
On February 17, 2015



Document number.
DC15-FTBLL12