

# Transducer Mounting Hole Machining Tool Kit Manual

# Operating Manual

## Introduction

The transducer Mounting Hole Machining Tool Kit contains all the necessary drills and taps to prepare a standard 1/2-20 UNF transducer mounting hole. The kit contains the special pilot drill required to machine the 45° seat. All tools included in this kit are made of premium grade strength tool steel. Care should be taken in the use of proper speeds and feeds, lubricants, and a method to assure continual alignment of each progressing tool. Consult Dynisco for additional information. M10 and M18 machining kits are also available.



Fig. 1 Cleaning Tool Kit Contents

- Step 1:** Drill a hole with the 9/32" drill.
- Step 2:** Ream the hole with the 5/16" reamer.
- Step 3:** Consult the mounting hole drawing and calculate the depth required for the 0.451"/0.458" hole to leave 0.225" minimum length of the 5/16" (0.312") diameter hole.
- Step 4:** Drill the 17/32" drill, if necessary, so as to leave approximately 1" of the 29/64" diameter hole length.
- Step 5:** Tap the 1/2-20 plug tap (tap with tapered lean) as deep as possible without striking the chamfered seating surface that was produced by the pilot drill.
- Step 6:** Tap the final depth with the 1/2-20 UNF bottoming tap.
- Step 7:** Examine the seating surface of the mounting hole. If it has been marked by the tapping operation, touch it up with the pilot drill.

It is generally good practice to check the mounting hole before installing the transducer. One procedure is to coat a gauge plug (P/N 200908) with Dykem blueing agent on the surfaces below the thread. Insert the gauge plug into the mounting hole and rotate the plug until surface binding is encountered. Remove and inspect. The blueing agent should be scraped off the 45° sealing chamfer. If blueing has been removed from other surfaces, the mounting hole has not been machined properly.

## Ordering Information

Part Number	Transducer Stem Size
200925	1/2-20 UNF
901949	M10
200205	M18

## Replacement Ordering Information

Part Number	Description
200924	29/94" Pilot Drill
200926	9/32" Drill (0.281)
200927	5/16" Reamer (0.3125)
200928	1/2-20 UNF GH5
200929	1/2-20 UNF GH5 Bottoming Tap
200930	17/32" Drill

Note: Gauge plug for PT435A, PT435A, PT467E, and PT465XL ordered separately. Refer to P/N 435901

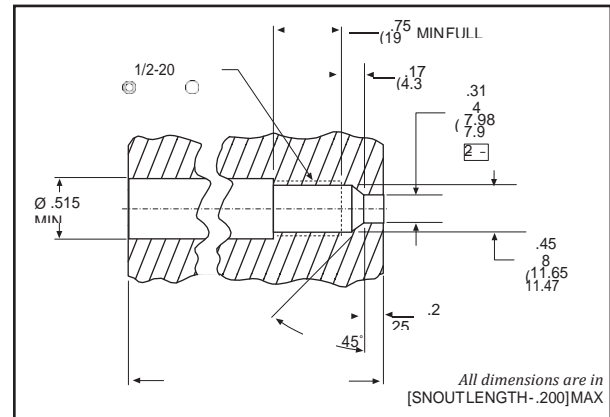

Fig. 2 Dimensional Diagram

## Repair

Questions concerning warranty, repair cost, delivery, and requests for a RA# should be directed to the Dynisco Repair Department, 508-541-9400 or email: [repair@dynisco.com](mailto:repair@dynisco.com). Please call for a return authorization number (RA#) before returning any product.

Dynisco, LLC  
Repair Department RA#  
38 Forge Parkway, Franklin, MA 02038

## Technical Assistance

Please call 800-221-2201 or 508-541-9400 or fax 508-541-9436.

## Warranty

Go to [www.dynisco.com](http://www.dynisco.com) and click on "Warranty" at the bottom of any page for complete details.