

LMI5500 Series

Melt Flow Indexer

*THE MOST ACCURATE MELT FLOW
INDEXER WORLDWIDE*



SHOWN WITH ALL AVAILABLE OPTIONS



MICROSOFT™ IOT ENABLED

Specifically designed for the thermoplastics resin industry, the LMI5500 has an array of features and benefits that range from ground-breaking accuracy to a unified software platform between all laboratory and online production equipment.

The LMI5500 brings a new level of ease of use with its easy to clean removable inspection plate, increased access for sample cutting, and revamped intuitive touch screen. Processors can obtain detailed analytics between lab and production data globally on a single dashboard with the Win10 IoT Core + Single Board Computer (SBC) platform with the integration of the Microsoft Cloud option.

The LMI is capable of delivering a wide range of data that includes not only melt flow rate, but also shear stress, shear rate, apparent viscosity, intrinsic viscosity and melt density, as well as testing conditions.

Features

- Gravitational correction
- New Windows 10 IoT touch screen native interface
- Built in WIFI and ethernet
- HDMI and multiple USB ports
- Direct digital scale USB interface for sample weighing
- Performance meets international standards: ASTM D1238 & D3364, ISO 1133-1, BS2782, DIN 53735, JIS K7210
- Automatic sample cutter for ease and consistency in sample cutting
- Melt Flow Rate to Intrinsic Viscosity correlation for PET
- Nearly unlimited program storage capability
- Increased access to the die for sample cutting with a strategically placed mirror to easily view the die and cutting area
- Supports multiple languages

Performance Characteristics	
Compliant Standards:	ASTM D1238 & D3364, ISO 1133-1 & ISO 1133-2, BS2782, DIN 53735, JIS K7210
Operating Temperature:	Ambient to 400 °C
Temperature Control:	±0.1 °C
Timer Accuracy:	0.001 S
Digital Encoder Accuracy:	±0.025mm over 25.4 mm
User Interface:	<ul style="list-style-type: none"> • 7" Touch Screen • 130° Viewing Angle • 800 x 480 Screen Resolution • Capacitive Touch Sensing
Weights:	Aluminum, Stainless or Plated Steel 0.325 to 31.6 Kg
Communication:	USB x 4, PC Connectivity, Scale Interface, Printing and Flash Storage
Dimensions	
Overall Dimensions, Base Model:	13W x 21D x 20H in. (33W x 53D x 51H cm)
Weight, Base Model:	47 lbs. (21.3 Kg)
Shipping Weight, Base Model with Weights:	180 lbs. (81.8 Kg)
Electrical Specifications	
System Voltage:	100-120Vac 50/60Hz or 220-240Vac 50/60Hz, 500VA, +5% , 1 single phase
Power:	500W max., 100W typical at set point

LMI Series Options

Dynisco IoT Cloud Console – Developed for processors to simply obtain detailed analytics and provides the ability to correlate laboratory and production rheological instruments for all devices globally on one single cloud dashboard and see any instrument around the world in real-time 24 hours a day, 7 days a week, 365 days a year.

Digital Encoder – The Digital Encoder provides a high precision measurement of piston displacement during Method A/B and B tests.

Automatic Sample Cutter – Cuts samples automatically at defined cut times of Method A and Method A/B Testing. Will also cut sample at end of pre-heat melt time of a test, regardless of method. Leads to more consistent sample cutting than cutting by hand.

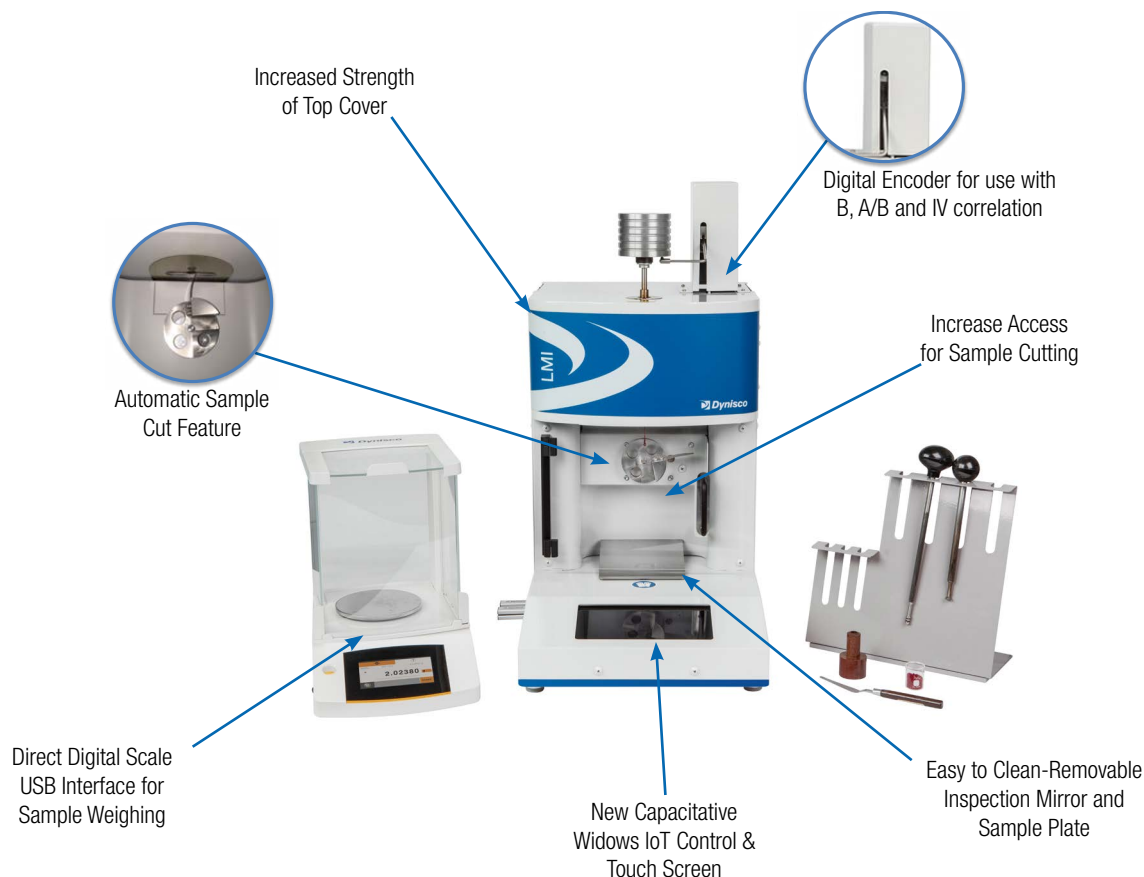

Ordering Guide

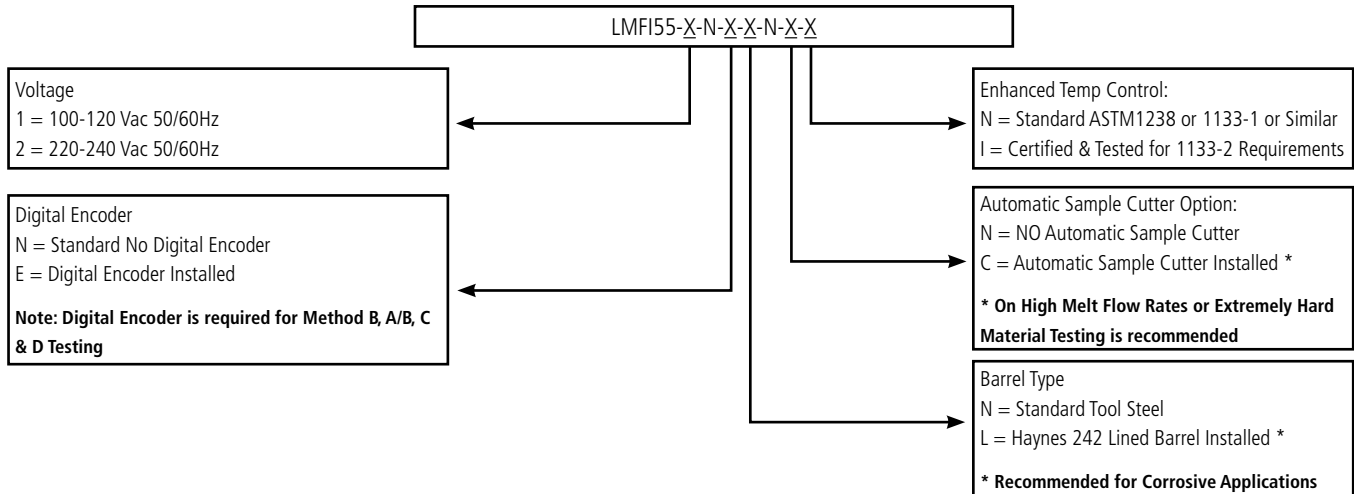

All dimensions are inches (mm) unless otherwise specified.
 ©2018. Dynisco reserves the right to make changes without notice.
 Refer to www.dynisco.com for access to Operator Manual and other support documentation. Microsoft is a trademark of Microsoft Corporation. All other trademarks are property of Dynisco.
 DSLMI5500
 Rev: 0918



Dynisco
 38 Forge Parkway
 Franklin, MA 02038
 USA

Hotline 1-800-Dynisco
www.dynisco.com
 Phone +1 508 541 9400
 Fax +1 508 541 6206
 Email infoinst@dynisco.com

Dynisco Europe, GmbH
 Pfaffenstr. 21
 74078 Hellbronn
 Germany

Phone +49 7131 297 0
 Fax +49 7131 297 166
 Email dyniscoeurope@dynisco.com

Dynisco Shanghai
 Building 7A, No. 568
 Longpan Rd Malu
 Jiading, 201801 China

Phone +86 21 34074072-819
 Toll Free +86 400 728 9117
 Fax +86 21 34074025