

PT415 Alternate Fill Pressure Sensors/Wash Down (NaK)

Operating Manual

Introduction

The PT415 provides a means of making pressure measurements up to 750F (400C). The transducer incorporates a four arm, 350 ohm Wheatstone bridge strain gage that gives an electrical output proportional to pressure. A calibration function is included which allows the transducer to be calibrated to a separate readout instrument.

Installation

The PT415 will provide excellent service and superior performance if proper care is taken during handling, installation and use. The most common causes of transducer damage are: installation in improperly machined or plugged mounting holes and cold starts.

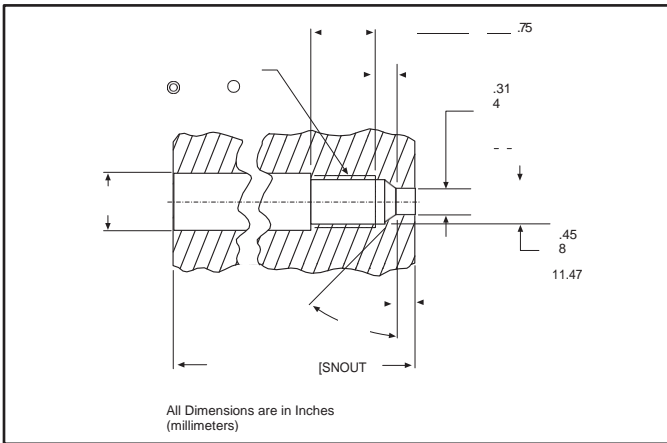

1/2-20 UNF Mounting Hole Diagram

Mounting Hole Preparation

When machining the mounting hole careful attention should be paid. A set of mounting hole-machining tools (Dynisco P/N 200925) is available with all necessary drills, taps, and reamers. Detailed instructions are given in Dynisco Bulletin (P/N 200925). It is generally good practice to check the mounting hole before installing the transducer with the Gauge Plug, P/N 200908.

Transducer Installation

To prevent galling, the transducer threads should be lubricated with a high temperature anti-seize compound. An adequate seal should be obtained with 100 inch-pounds of mounting torque. The maximum recommended torque is 500 inch-pounds. The Dynisco Cleaning Tool Kit, P/N 200100, should be used to keep the mounting hole free of foreign material when reinstalling the transducer.

Wiring

The PT415 is connected to external signal conditioning/readout instrumentation with a six wire shielded cable integral to the transducer (or optional 6-pin connector, Bendix PT1H-10-6P). The mating connector is the Bendix PT06W-10-6S (Dynisco P/N 711610).

Function	PT415
Signal +	Red (A)
Signal -	Black (B)
Excitation +	White (C)
Resistor	Green (D)
Internal Cal	Blue (E)
Resistor	Orange (F)

Operation

Allow the transducer to reach operating temperature. With no pressure applied, follow recommended procedures with instrumentation for zero and span adjustment. Standard transducers are supplied with and R-CAL of 80%. The special all-welded stainless steel construction of the PT415 will withstand washdown as long as there is proper electrical installation through conduit or waterproof junction box. Or, in the case of the hermetic connector, the connection is made with appropriate weathertight mating connector.

Start-Up

It is very important to allow sufficient "soak time" to assure that the medium at the tip of the transducer is molten before the extruder drive is started.



Application Note:

The model PT415 incorporates a NaK (sodium-potassium) fill for excellent high-temperature performance and process capability. The NaK in the capillary filled system is contained and is an extremely small volume (less than 0.004 cubic inches). In the event of damage to the transducer, any NaK released would rapidly oxidize. Oxides of NaK are water-soluble, and the byproducts are non-toxic.

It is the responsibility of the user to determine the compatibility of these transducers with their process. These transducers are not suitable for areas, which have a hazardous area classification.

Transducer Repair

Questions concerning warranty, repair cost, delivery, and requests for a RA# should be directed to the Dynisco Repair Department, 508-541-9400 or email: repair@dynisco.com. Please call for a return authorization number (RA#) before returning any product. Damaged transducers should be returned to:

Dynisco Instruments
Attn: RA# _____
38 Forge Parkway
Franklin, MA 02038

Technical Assistance

Please call 800-221-2201 or 508-541-9400 or fax 508-541-9436.

Warranty

This Dynisco product is warranted under terms and conditions set forth in the Dynisco Web Pages. Go to www.dynisco.com and click on "Warranty" at the bottom of any page for complete details.

Dynisco

38 Forge Parkway Franklin, MA 02038

Tel: 508.541.9400 Fax: 508.541.9436

www.dynisco.com