

Transducer Mounting Hole Cleaning Tool Kit



Important

The cleaning tool must be used when the polymer is in a semi - molten state. Care must be taken not to exceed a torque rating of 100 inch - pounds during scraping so as not to damage the cutting edges of the tool. These cutting edges are manufactured from hardened tool steel and will not wear if reasonable care is exercised. It is strongly recommended that a high temperature lubricant be applied to the tap and the threads of the guide sleeve and gauge plug to prevent seizing.

Description

The cleaning tool kit was designed by Dynisco for use in removing excess plastic from mounting holes for pressure and temperature transducers. Installation of transducers into improperly cleaned or sized holes is one of the major causes of damage to these instruments. With this kit, the .312" tip diameter hole, the 45 degree seating surface, and the .451" hole can be cleaned. The kit includes a gauging plug which is used to verify that the hole has been correctly machined and cleaned. M10 and M18 cleaning kits also available.

Suggested Procedure

- Step 1:** Clean threads of hole with four - fluted bottoming tap until threads are clean.
- Step 2:** Thread the guide sleeve/cleaning drill into the hole. Finger tight is sufficient. In a clockwise motion, push and turn cleaning drill so that the residue is scraped from critical surfaces. Do not rock tool back and forth. Remove tool and clean off residue. Reinsert tool and scrape again. Continue this operation until tool is clean when removed.
- Step 3:** Apply Dykem blueing on gauge plug surfaces below thread. Insert the gauge plug into the hole and rotate until surface binding is encountered. Remove and inspect. Blueing should only be scraped off 45 degree sealing chamfer. If blueing is removed from other surfaces, then mounting hole is not clean or has not been machined properly.

Ordering Guide for Transducer Mounting Hole Cleaning Tool Kit

Part Number-
200100
Weight-
5.5 lbs.

With this kit the .312" tip diameter hole, the 45 degree seating surface and the .451" hole can be cleaned. A gauging plug is included to verify that the hole has been correctly machined and cleaned. All tools are contained in a convenient carrying case. Specify P/N200102 for an M10 cleaning tool kit or P/N200101 for an M18 kit.

Replacement Parts

2009XX

Delivery

All configurations express delivery.

Part Number
04 = Cleaning Drill
05 = Bottoming Tap
06 = Cleaning Drill Guide
07 = Handle
08 = Gauge Plug
09 = Allen Hex Wrench
10 = Dykem Blue

Gauge plug included with cleaning tool kit. Refer to P/N900908 to order additional plugs.
Gauge plug for PT435A, PT467E, and PT465XL ordered separately, refer to P/N435901.

Dimensions

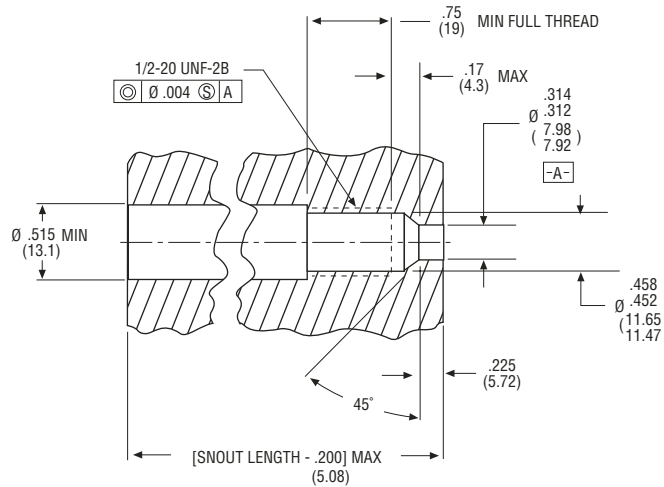

All dimensions are inches (mm) unless otherwise specified.
©2016. Dynisco reserves the right to make changes without notice.
Refer to www.dynisco.com for access to Operator Manual and other support documentation.
DSMDT4X2FSILZ
Rev: 1216

www.dynisco.com

Dynisco
38 Forge Parkway
Franklin, MA 02038
USA
Hotline 1-800-Dynisco
www.dynisco.com
Phone +1 508 541 9400
Fax +1 508 541 6206
Email infoinst@dynisco.com

Dynisco Europe, GmbH
Pfaffenstr. 21
74078 Hellbronn
Germany
Phone +49 7131 297 0
Fax +49 7131 297 166
Email dyniscoeurope@dynisco.com

Dynisco Shanghai
Building 7A, No. 568
Longpan Rd Malu
Jiading, 201801 China
Phone +86 21 34074072-819
Toll Free +86 400 728 9117
Fax +86 21 34074025