



Instructions for the 800 Series of Strain Gage Pressure Transducers and Transmitters

Operating Manual



CONTENTS

1. Description	3
2. Model Number Construction	3
3. Pressure Fitting	3
4. Electrical Connections	4
5. Electrical Connections and Wiring	5
6. Operation and Calibration	7
7. Repair	7
8. Warranty	7



1. DESCRIPTION

Dynisco's 800 Series of Pressure Transducers and Transmitters are bonded foil strain gage type, designed to measure pressures up to 60,000 psi. These transducers convert changes in applied pressure into corresponding changes in output voltage or current.

2. MODEL NUMBER CONSTRUCTION

The model number designates the features of the 800 Series pressure transducers.

Model 1234X-567-8-9

- 1 = Pressure Reference
 - 2 = 800 Series
 - 3 = Full Scale Output
 - 4 = Accuracy
 - X = Approval
 - 5 = Pressure Port Thread
 - 6 = Electrical Termination
 - 7 = Wiring
 - 8 = Pressure Range*
 - 9 = Options
- *Pressure range is noted on label.

For complete details, refer to the individual ordering guides for each model.

3. PRESSURE FITTING (POSITION 5 OF MODEL NUMBER)

The pressure port thread of the standard 800 Series (Code 0 in the model number) is internal 1/8 -27 NPT fabricated from high strength stainless steel.

Options available include the following:

Code in Model No.	Description
1	1/4 -18 NPT, internal
2	7/16 -20 UNF, internal, O-ring, per MS33649-4
3	High Pressure, internal fitting per autoclave F-250-C



- 4 1/4 -18 NPT, external
- 5 1/2 -14 NPT, external
- 6 7/16 -20 UNF, external, per MS33656-4
- 7 R 1/4 -metric, external
- 8 3/4 -16 UNF, external, flush diaphragm**
- 9 Special (consult factory)
- A 7/16 -14 BSP, external
- B 7/16 -14 NPSM, external
- C Autoclave F-562-C
- D 1" BSP, internal
- G Autoclave F-375C

**Each flush diaphragm transducer or transmitter is shipped with a DYNASEAL™, Dynisco P/N 633014, for the pressure port seal. Recommended torque, for an adequate seal, is 100 in-lbs. Care should be exercised with the low pressure ranges. The flush diaphragm can be inadvertently overloaded with thumb pressure, which can be the equivalent of several hundred psi.

4. ELECTRICAL CONNECTIONS (POSITION 6 OF MODEL NUMBER)

Code 0 in the model number — Standard 800 Series models have a Bendix Connector PT02A-10-6P (or equivalent) and require mating connector PT06W-10-6S (SR) (Dynisco P/N 711600).

Code 1 in the model number — 800 Series Models with the weathertight option include Bendix PT02H-10-6P (or equivalent) and require mating connector PT06W-10-6S (Dynisco P/N 711610).

Code 3 in the model number — Option for the 1/2 -14 NPT conduit fitting with the 4 ft six conductor cable.

WIRING CODE — Transducers

Function	Pin	Color
Output (+)	A	Red
Output (-)	B	Black
Input (+)	C	White
Input (-)	D	Green
Shunt Cal.	E, F	Blue, Orange

Code 4 in the model number — 800 Series can come equipped with 1/2 -14 NPT conduit fitting and three 42" leads.



WIRING CODE — Transmitters

Function Pin Color

Supply Voltage (+)	A	Red
Supply Voltage (-)	B	Black
Case Ground		Green

Transmitters incorporate reverse polarity protection, but will not function if inputs are reversed.

ALL WIRING MUST CONFORM TO NATIONAL ELECTRICAL CODE.

5. ELECTRICAL CHARACTERISTICS AND WIRING

Fig. 1 Power Supply Requirements and Typical Wiring Diagrams

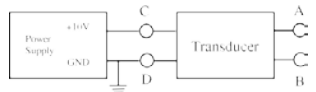
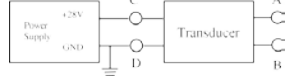
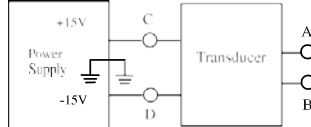
TRANSDUCER MODEL	OUTPUT	POWER SUPPLY	WIRING DIAGRAM
830 831 832	3 mV/V	10 Vdc (Recommend) 15 Vdc (Maximum)	
850/851 860/861	0 – 5 Vdc 0 -10 Vdc	Single 24 n 32 Vdc	
850/851 860/861	0 – 5 Vdc 0 -10 Vdc	Split 85X 12 -16 86X 14-16	

MODELS 830/831/832

Transducers with 3 mV/V output require a well regulated power supply and have a nominal load of 350 ohms. The mV readout should present a high impedance input and have good common mode rejection. Use of six conductor shielded cable (like Dynisco P/N 800024) is recommended to minimize noise pickup.

Fig. 2 Schematic for 830/831/832

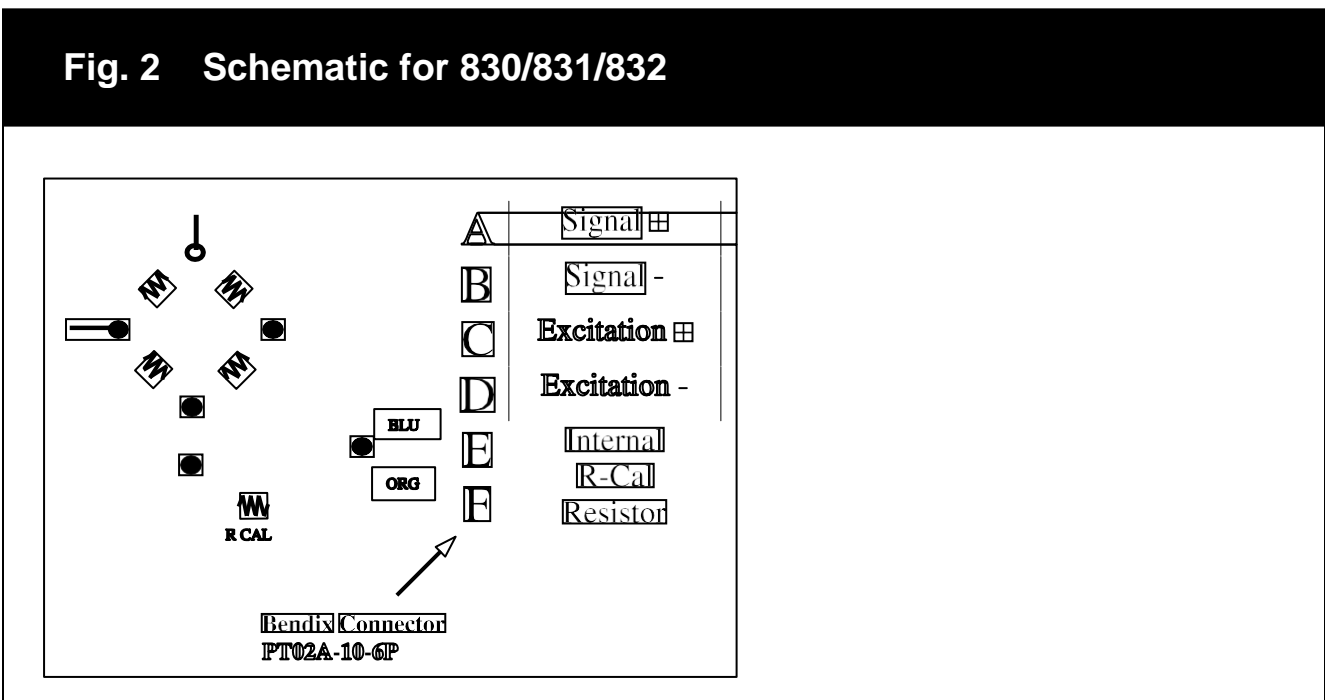

MODELS 840/841/850/851/860/861

Dynisco high level output transducers and transmitters have a voltage regulator, signal conditioner, and amplified incorporated within the device. These models have accessible ZERO and SPAN adjustments. These are factory set and should not require adjustment.

Voltage output devices have a current drain of 45mA maximum at recommended minimum load of 2000 ohms.

CONDUIT FITTING — Units with the 1/2 -14 NPT conduit fitting and leads or cable, should be installed using appropriate conduit or junction box in conformance with local codes. This is essential for environmental protection of the electrical termination.



6. OPERATION AND CALIBRATION

After the transducer and the readout have been installed, the system must be calibrated using either a precision pressure source such as a dead-weight tester, or by using the shunt calibration function.

PRESSURE CALIBRATION — With no pressure applied, the signal conditioner ZERO control (or ZERO adjustment of high level output transducers) is adjusted for zero pressure indication on the readout. With a known pressure applied to the transducer (typically 80 to 100% of full scale), the signal conditioner SPAN control (or SPAN adjustment of high level output transducers) is adjusted for the correct readout of the applied pressure.

SHUNT CALIBRATION — All 800 Series pressure transducers (except 840/1 transmitters) contain an internal Shunt Calibration resistor (R-CAL) which provides a simulated output of 80% of full scale when pins E and F are shorted. Do not apply pressure to the transducer during calibration. Refer to instructions with the instrumentation for details on ZERO and SPAN adjustment.

7. REPAIR

Questions concerning warranty, repair cost, delivery, and requests for a RA# should be directed to the Dynisco Repair Department, 508-541-9400 or email: repair@dynisco.com. Please call for a return authorization number (RA#) before returning any product. Damaged products should be returned to:

DYNISCO LLC

Attn: RA # _____

38 Forge Parkway
Franklin, MA 02038

For technical assistance please call 800-DYNISCO or 508-541-9400 or fax 508-541-9436.

8. WARRANTY

This Dynisco product is warranted under terms and conditions set forth in the Dynisco Web Pages. Go to www.dynisco.com and click on “Warranty” at the bottom of any page for complete details.